

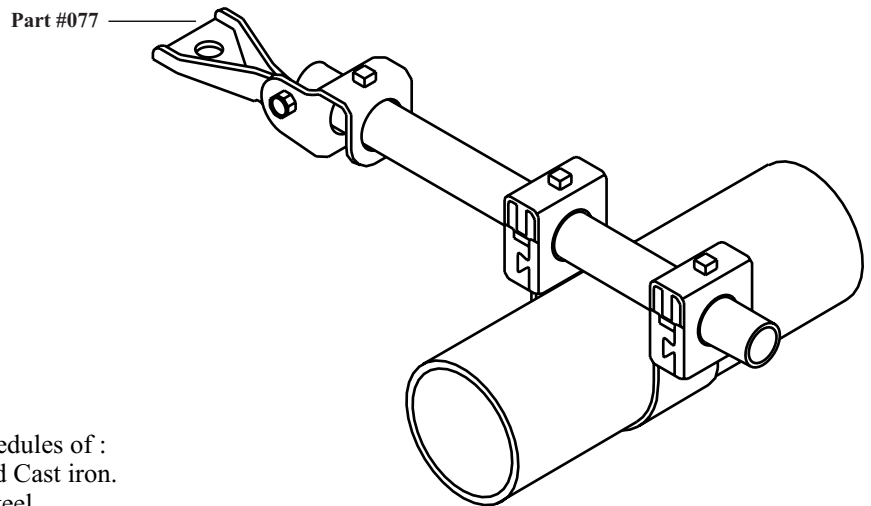

030/040

SWAY BRACE MODEL K



SIZE - Pipe to be braced: 1" thru 10" - All Schedules of :
Steel, CPVC, Copper, Plastic, FRP, Ductile and Cast iron.
Consult factory when bracing pipe other than steel.

Pipe used for bracing: 1" and 1 1/4" threadable lightwall thru Sch.40.

MATERIAL - Carbon Steel.

FINISH - Plain, Electro-Galvanized and H.D.G.

LISTINGS -

EX 2625
cULus Listed only for use with other *AFCON* bracing products.
OSHDP pending.

PATENT - No. 4,697,770
No. 6,508,441

FUNCTION - The sprinkler pipe attachment component of a lateral sway brace assembly, consisting additionally of *AFCON* 70 series attachment end, *AFCON* 80 series adapter as required and brace pipe element forming a complete sway brace assembly.

INSTALLATION - Per NFPA-13. Place Model K over pipe to be braced. Insert brace pipe through MODEL "K", leaving 1" minimum extension beyond. Tighten set screws until heads contact the bracket.

FEATURES

- * UL Horizontal Load Rating: 2765#, All sizes
- * Patented design for use with multiple piping materials.
- * Visual inspection, proper installation when set screw heads contact bracket.
- * Can be used as a 4-way sway brace.

ORDERING - Part #, pipe size to be braced, brace pipe size and finish.

