

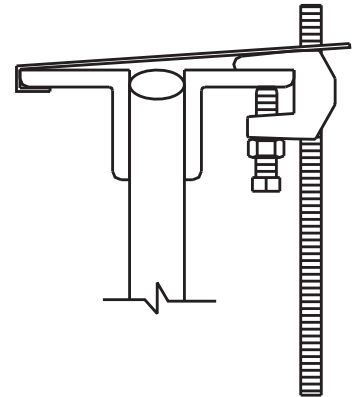

P.O. Box 3365 South El Monte, CA 91733 626.444.0541 Fax 626.444.3887 www.Afcon.org

100

REVERSIBLE BEAM CLAMP 3/4" MOUTH

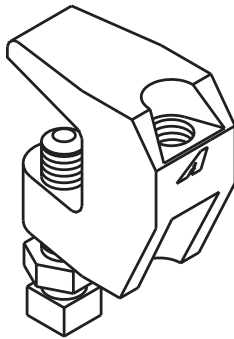

SIZE - ROD: 3/8" SIZE - SYSTEM PIPE: 4" max.
SIZE - ROD: 1/2" SIZE - SYSTEM PIPE: 8" max.

MATERIAL - Ductile iron.
FINISH - Plain, E.G. and H.D.G.
LISTING/APPROVAL -



FUNCTION - Attachment component of an *AFCON* hanger.
To support horizontal piping.
INSTALLATION - Per NFPA 13 and these instructions.
Install on steel flange - thickness less than 3/4".
Set bolt up or down.

ASSEMBLY/ATTACHMENT - See drawing.
Torque - 3/8"= 60 lb-in or 1/2"= 125 lb-in.
In the absence of a torque wrench, engage set bolt finger tight then additionally tighten 1/4 turn.
Only tighten set bolt with hand tools.
NEVER INSTALL SET BOLT WITH IMPACT/DRILL DRIVER.

FEATURES
* Maintains **CONSTANT HANGER CENTER-LINE**, with set bolt up or down.
* **Flat throat back** to prevent twisting on structure during installation.
ORDERING - Part #, rod size and finish.

