

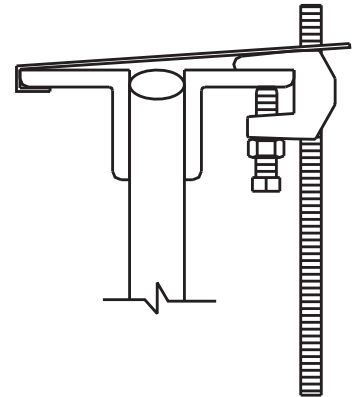

P.O. Box 3365 South El Monte, CA 91733 626.444.0541 Fax 626.444.3887 www.Afcon.org

105

REVERSIBLE BEAM CLAMP 1 1/4" MOUTH

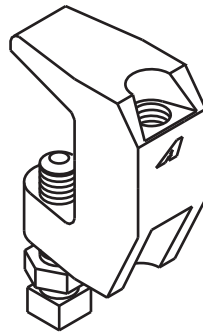

SIZE - ROD: 3/8" **SIZE - SYSTEM PIPE:** 4" max.
SIZE - ROD: 1/2" **SIZE - SYSTEM PIPE:** 8" max.

MATERIAL - Ductile iron.

FINISH - Plain, E.G. and H.D.G.

LISTING/APPROVAL -



FUNCTION - Attachment component of an *AFCON* hanger.

To support horizontal piping.

INSTALLATION - Per NFPA 13 and these instructions.

Install on steel flange - thickness less than 1 1/4".

Set bolt up or down.

ASSEMBLY/ATTACHMENT - See drawing.

Torque - 3/8"= 60 lb-in or 1/2"= 125 lb-in.

In the absence of a torque wrench, engage set bolt finger tight then additionally tighten 1/4 turn.

Only tighten set bolt with hand tools.

NEVER INSTALL SET BOLT WITH IMPACT/DRILL DRIVER.

FEATURES

* Maintains **CONSTANT HANGER CENTER-LINE**, with set bolt up or down.

* **Flat throat back** to prevent twisting on structure during installation.

ORDERING - Part #, rod size and finish.

