

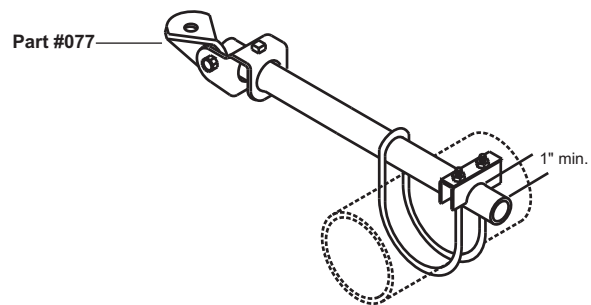

P.O. Box 3365 South El Monte, CA 91733 626.444.0541 Fax 626.444.3887 www.Afcon.org

001/020

SWAY BRACE FITTING MODEL E

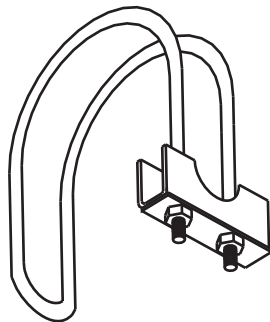

SIZE - SYSTEM PIPE: Nominal
Steel 1" thru 4" Sch. 10 and Sch. 40
SIZE - BRACE PIPE: 1" or 1 1/4" Sch. 40
MATERIAL - Carbon Steel or S.S. (Type 304).
FINISH - Plain or E.G.
LISTING/APPROVAL -

FM Approved - 1950
OSHPD See Website.

Max. ASD Horizontal Load					
System NPS	Sch.	30°-44°	45°-59°	60°-74°	75°-90°
1"	40	430	610	750	840
1 1/4" - 1 1/2"	LW - 40	90	130	160	180
2"	LW	190	280	340	380
2"	10	550	790	960	1080
2"-3"	40	500	710	870	970
2 1/2" - 4"	LW	160	230	280	320
2 1/2" - 4"	10	260	370	460	510
4"	40	1030	1460	1790	1990

FUNCTION - Lateral fitting of an *AFCON* sway brace assembly.

INSTALLATION - Per these instructions
including NFPA 13 and FM 2-8.

Load rating - see chart.

ASSEMBLY - See drawing.

Combine with proper *AFCON* components- **see disclaimer below.**
Insert brace pipe through rod bend and under channel bracket
to achieve minimum 1" extension.

Tighten hex nuts until gage spring lays flat or torque to 165 lb-in.

FEATURES

* Visual inspection, verifies proper installation.

ORDERING - Part #, size - system pipe, size - brace pipe and finish.

Specific *AFCON* products are exclusively designed to be compatible **ONLY** with other *AFCON* products including parts and fasteners, resulting in a listed sway brace, restrainer or hanger assembly. **Be advised** the following warranty restriction will apply. **DISCLAIMER -** *AFCON* will **NOT** warrant against the failure of its products when used in combination with other products, parts or systems not manufactured or sold by *AFCON*. *AFCON* shall **NOT** be liable under any circumstances whatsoever for any direct or indirect, incidental or consequential damages of any kind, including but not limited to loss of business or profit, when non-*AFCON* products have been, or are used.

