

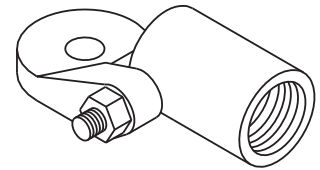

P.O. Box 3365 South El Monte, CA 91733 626.444.0541 Fax 626.444.3887 www.Afcon.org

070

ATTACHMENT FITTING THREADED

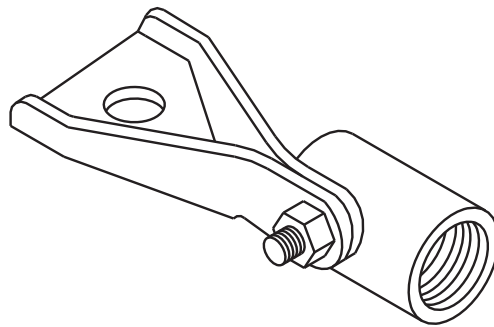

SIZE - 1 thru 2 inch bracing pipe.

Use in combination with 1 thru 10 inch *AFCON* sway brace assemblies.

MATERIAL - Carbon steel and ductile iron

FINISH - Plain or E.G.

LISTING/APPROVAL -

 **203A-EX 2625**

Listed only for use with other *AFCON* bracing products.

OSHPD OPA-0601 See Website.

FUNCTION - Structure attachment fitting of a sway brace assembly, consisting additionally of *AFCON* 001 thru 040 sway brace fitting and brace element forming a complete sway brace assembly.

INSTALLATION - Per NFPA 13. **Listed for use with NFPA 13 fastener tables.** For installation on H-beam or steel web joist see *AFCON* 085 thru 088 sway brace adapters.

ASSEMBLY - Tightly thread pipe brace element into fitting.

FEATURES

- * UL Horizontal Load Rating: 2765#, All Sizes
- * Swivel design allows attachment at any angle.
- * May be ordered with larger fastener hole. - Consult Factory.

ORDERING - Part #, pipe size and finish.

Specific *AFCON* products are exclusively designed to be compatible **ONLY** with other *AFCON* products including parts and fasteners, resulting in a listed sway brace, restrainer or hanger assembly. **Be advised** the following warranty restriction will apply. **DISCLAIMER** - *AFCON* will **NOT** warrant against the failure of its products when used in combination with other products, parts or systems not manufactured or sold by *AFCON*. *AFCON* shall **NOT** be liable under any circumstances whatsoever for any direct or indirect, incidental or consequential damages of any kind, including but not limited to loss of business or profit, when non-*AFCON* products have been, or are used.

