

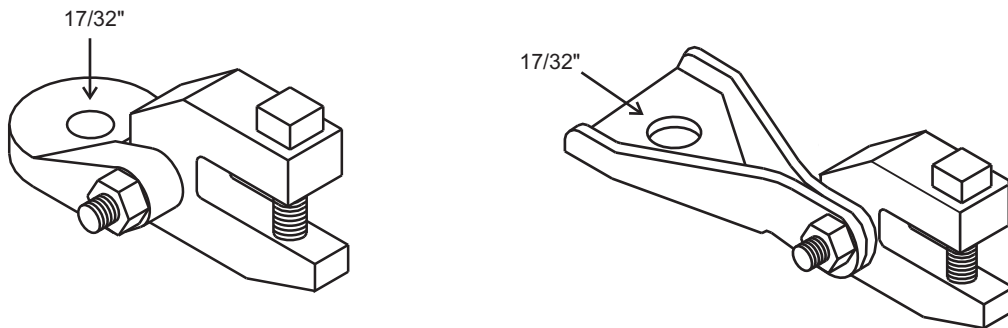

P.O. Box 3365 South El Monte, CA 91733 626.444.0541 Fax 626.444.3887 www.Afcon.org

076

## ATTACHMENT FITTING UNIVERSAL LOCKING



**SIZE - BRACE PIPE** - 1" thru 2" Sch. 40

May be used with strut channel and structural steel.

**MATERIAL** - Ductile iron and Carbon Steel .

**FINISH** - Plain or E.G.

**LISTING/APPROVAL** -

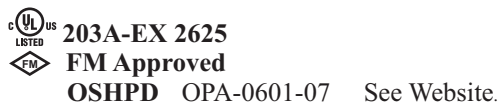

**FUNCTION** - Structure attachment fitting of an *AFCON* sway brace assembly.

Sway brace assemblies are intended to be installed in accordance with NFPA 13 and the manufacturer's installation instructions.

**INSTALLATION** - Per these instructions including NFPA 13 and 13R.

**Load rating** - see chart.

The required type number and size of fasteners used for the structure attachment fitting shall be in accordance with NFPA 13.

### ASSEMBLY

Combine with proper *AFCON* components.

Insert brace element into fitting snug against back of jaw.

Install set bolt finger tight, then additionally tighten 1 1/2 turns or torque to 40 ft. lbs.

Torque pivot bolt to 40 ft. lbs.

### FEATURES

\* Swivel allows attachment at any angle.

\* Larger fastener hole available.- Consult factory.

**ORDERING** - Part #, pipe size, material and finish.

Horizontal Load Ratings		
Base Material	FM	UL
Ductile	3250	2765
Steel	---	2015

Specific *AFCON* products are exclusively designed to be compatible **ONLY** with other *AFCON* products including parts and fasteners, resulting in a listed sway brace, restrainer or hanger assembly. **Be advised** the following warranty restriction will apply. **DISCLAIMER** - *AFCON* will **NOT** warrant against the failure of its products when used in combination with other products, parts or systems not manufactured or sold by *AFCON*. *AFCON* shall **NOT** be liable under any circumstances whatsoever for any direct or indirect, incidental or consequential damages of any kind, including but not limited to loss of business or profit, when non-*AFCON* products have been, or are used.