

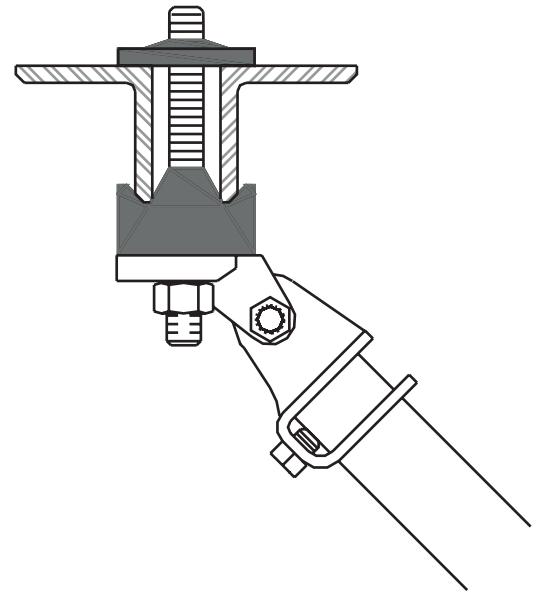

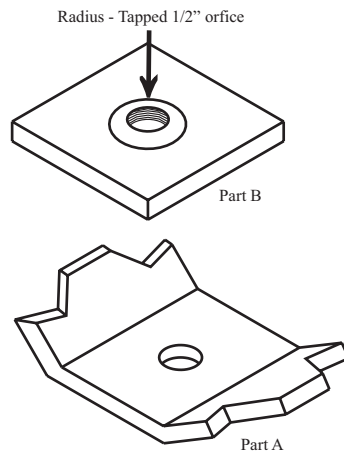

P.O. Box 3365 South El Monte, CA 91733 626.444.0541 Fax 626.444.3887 www.Afcon.org

085

## SWAY BRACE ADAPTER



**SIZE** - 1/2" stud.  
**MATERIAL**- Carbon Steel.  
**FINISH** - Plain or E.G.  
**PATENT** - No. 6,749,359  
**LISTING/APPROVAL** -

 203A-EX 2625, 203-EX 2551  
**Listed only for use with other AFCON bracing products.**  
**OSHDP** OPA-0601-07 See Website.

**FUNCTION** - Sway brace adapter for an **AFCON** sway brace assembly.  
 Designed to stabilize a 1/2" stud in the chord space of a steel structural member.  
 Sway brace assemblies are intended to be installed in accordance with NFPA 13 and the manufacturer's installation instructions.  
 Additionally listed as an 8" hanger attachment.

**INSTALLATION** - Per NFPA 13 and these instructions.

**Load rating - see chart.**

Combine with proper **AFCON** components.

The structural members design will dictate specific attachment criteria.

**ASSEMBLY** - See drawing.

Insert 1/2" threaded stud thru chord space into tapped part B. Install part A over stud, engage **AFCON** sway brace assembly and nut. Engage mounting nut finger tight, then additionally tighten 1 1/2 turns or torque to 40 ft. Lbs.

\* Stud and nut furnished by customer.

### FEATURES

\* Radius - Tapped 1/2" orifice facilitates thread engagement.

**ORDERING** - Part # and finish.

| Horizontal Load Ratings    | UL   |
|----------------------------|------|
| Parallel 30° thru 90°      | 2015 |
| Perpendicular 30° thru 90° | 2015 |

Specific **AFCON** products are exclusively designed to be compatible **ONLY** with other **AFCON** products including parts and fasteners, resulting in a listed sway brace, restrainer or hanger assembly. **Be advised** the following warranty restriction will apply. **DISCLAIMER** - **AFCON** will **NOT** warrant against the failure of its products when used in combination with other products, parts or systems not manufactured or sold by **AFCON**. **AFCON** shall **NOT** be liable under any circumstances whatsoever for any direct or indirect, incidental or consequential damages of any kind, including but not limited to loss of business or profit, when non-**AFCON** products have been, or are used.

