

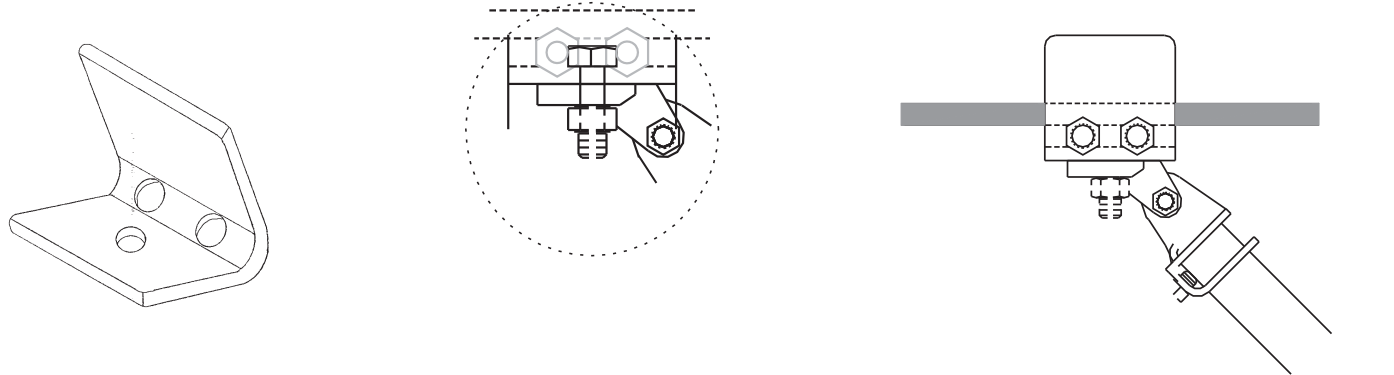

P.O. Box 3365 South El Monte, CA 91733 626.444.0541 Fax 626.444.3887 www.Afcon.org

086

### SWAY BRACE ADAPTER



**SIZE** - 1/2" x 1 1/4" bolt.  
**MATERIAL** - Carbon Steel.  
**FINISH** - Plain or E.G.  
**PATENT** - No. 6,334,285  
**LISTING/APPROVAL** -

 203A-EX 2625, 203-EX 2551 **OSHPD** See Website

**FUNCTION** - Sway brace adapter for an *AFCON* sway brace assembly.  
Designed to attach to the horizontal flanges of a steel structural member.  
Additionally listed as an 8" hanger attachment.

**INSTALLATION** -Per these instructions including NFPA 13.

**Load rating** - see chart.

Combine with proper *AFCON* components- see disclaimer below.

The structural members design will dictate specific attachment criteria.

**ASSEMBLY** - See drawing.

Insert 1/2" x 1 1/4" attachment bolt in **086** bracket. Install 1/2" studs thru both brackets and engage on steel flange. Install nuts on studs finger tight, then additionally tighten 1 1/2 turns or torque to 40 lb-ft.

**Only tighten nut with hand tools.**

**NEVER INSTALL NUT WITH IMPACT/DRILL DRIVER.**

Attach *AFCON* sway brace assembly on 1/2" bolt.

\* *Studs, fasteners and bolt furnished by customer.*

**FEATURES**

- \* Fits 1/4" thru 1 1/4" flange thickness.
- \* Studs capture head of bolt, providing hold back.
- \* Alternative to center loading beam clamp.

**ORDERING** - Part # and finish.

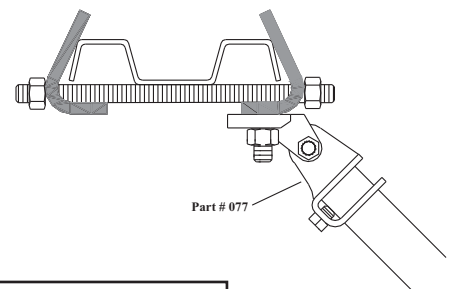
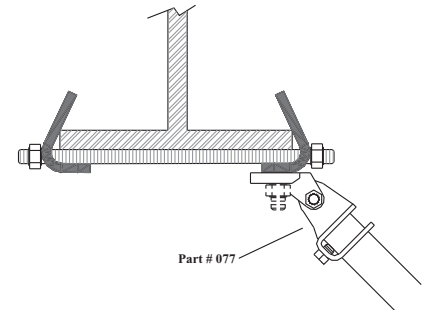

	<b>Max. Horizontal Load</b>	
	Parallel 30° thru 90°	1265
	Perpendicular 30° thru 90°	2015



Specific *AFCON* products are exclusively designed to be compatible **ONLY** with other *AFCON* products including parts and fasteners, resulting in a listed sway brace, restrainer or hanger assembly. **Be advised** the following warranty restriction will apply. **DISCLAIMER** - *AFCON* will **NOT** warrant against the failure of its products when used in combination with other products, parts or systems not manufactured or sold by *AFCON*. *AFCON* shall **NOT** be liable under any circumstances whatsoever for any direct or indirect, incidental or consequential damages of any kind, including but not limited to loss of business or profit, when non-*AFCON* products have been, or are used.

