

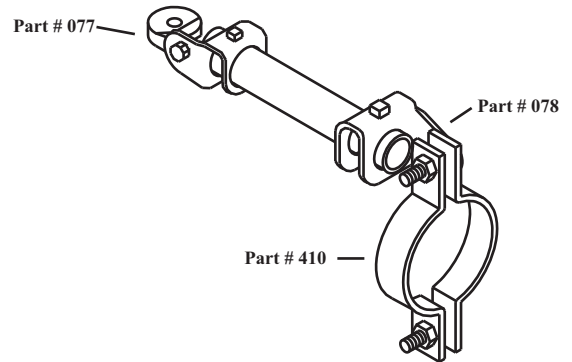

P.O. Box 3365 South El Monte, CA 91733 626.444.0541 Fax 626.444.3887 www.Afcon.org

# 410

## SWAY BRACE FITTING

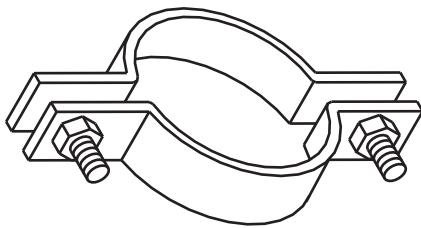

**SIZE** - 1 thru 8 inch pipe.

**MATERIAL** - Carbon Steel or S.S. (Type 304).

**FINISH** - Plain, E.G., and H.D.G.

**LISTING/APPROVAL** -

 **203A-EX 2625, 203-EX 2551**

**Listed only for use with other AFCON bracing products.**

**OSHPD** OPA-0601 See Website.

**FUNCTION** - Pipe attachment component of a longitudinal or 4-way sway brace, consisting additionally of *AFCON* 70 series attachment end, *AFCON* 80 series adapter as required and brace pipe element forming a complete sway brace assembly.

**INSTALLATION** - Per NFPA 13. Assemble **410** over pipe to be braced, install **70** series attachment end on outside of clamp ears and tighten bolts to minimum required torque of 40 ft.lbs.

*078 is the preferred assembly component for use with the 410 - see drawing.*

**FEATURES**

- \* UL Horizontal Load Rating: 1-3 pipe size = 500#  
4-8 pipe size = 2015#

\* Made with 1/2" bolts to conform with sway brace fittings.

**ORDERING** - Part #, pipe size and finish.

Specific *AFCON* products are exclusively designed to be compatible **ONLY** with other *AFCON* products including parts and fasteners, resulting in a listed sway brace, restrainer or hanger assembly. **Be advised** the following warranty restriction will apply. **DISCLAIMER** - *AFCON* will **NOT** warrant against the failure of its products when used in combination with other products, parts or systems not manufactured or sold by *AFCON*. *AFCON* shall **NOT** be liable under any circumstances whatsoever for any direct or indirect, incidental or consequential damages of any kind, including but not limited to loss of business or profit, when non-*AFCON* products have been, or are used.

