

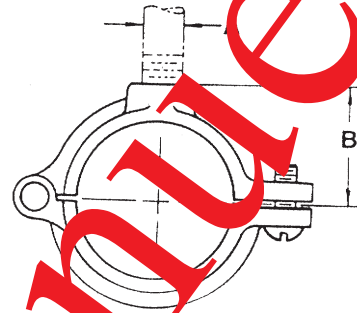

P.O. Box 3365 South El Monte, CA 91733 626.444.0541 Fax 626.444.3887 www.Afcon.org

350

### SPLIT RING - EXTENSION

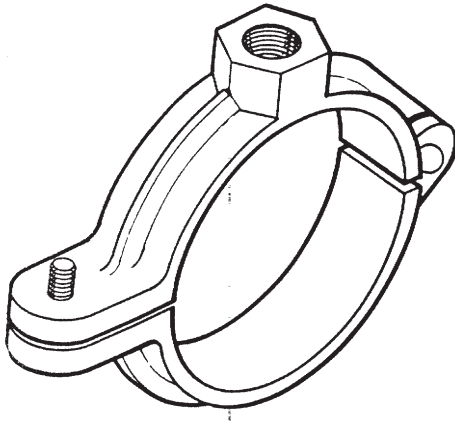

PIPE SIZE	ROD SIZE		MAX REC. LOAD LBS. *
	A	B	
1	3/8	1 1/8	180
1 1/4	3/8	1 5/16	180
1 1/2	3/8	1 3/8	180
2	3/8	1 11/16	180
2 1/2	1/2	2 3/16	300
3	1/2	2 1/2	300

NOTE: Maximum Temperature: 450°F

**SIZE** - 1 thru 3 inch pipe.

**MATERIAL** - Ductile Iron.

**FINISH** - Plain, E.G. and H.D.G.

**LISTING/APPROVAL** - conforms to Federal Specification WW-H-171E, type 25, and Manufacturers Standardization Society SP-69, type 12.

**OSHPD** - OPA-0601 See Website.

**FUNCTION** - A right support to hold pipe away from mounting surface.