

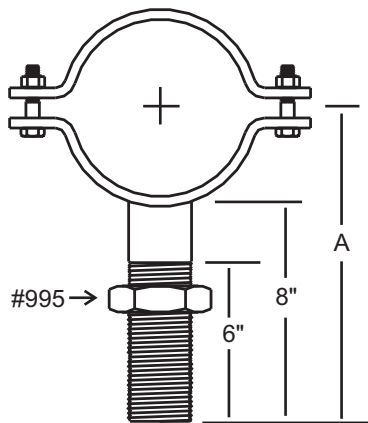

P.O. Box 3365 South El Monte, CA 91733 626.444.0541 Fax 626.444.3887 www.Afcon.org

708

ADJUSTABLE PIPE SUPPORT WITH #415 PIPE CLAMP



| PIPE SIZE | 995 SIZE | A | WEIGHT/C (APPROX) |
|-----------|----------|----------|-------------------|
| 4 | 1 1/2 | 10 5/8 | 400 |
| 6 | 1 1/2 | 11 11/16 | 488 |
| 8 | 2 | 12 11/16 | 737 |
| 10 | 2 | 13 3/4 | 844 |

SIZE - 4 thru 10 inch pipe.

MATERIAL - Carbon Steel.

FINISH - Plain and E.G.

ENGINEERED - Per NFPA 13.

Certified by registered professional engineer - Available upon request.

MAXIMUM TEMP. - 650°F

FUNCTION - To support and capture horizontal pipe.

INSTALLATION - Per NFPA 13.

ORDERING - Part #, pipe size, and finish.

